

## DIAPHRAGM SENSING PRESSURE SUSTAINING VALVE

### PS30SS

1/2" – 2"; DN 15 – DN 50

#### DESCRIPTION

The ADCA PS30 series direct acting, spring-loaded diaphragm sensing, pressure sustaining valves are designed for use on compressed air, water, and other gases or liquids compatible with the materials of the construction.

They are suitable for pressure sustaining applications where low capacity is required.

This valve main purpose is to maintain the upstream pressure under control.

#### MAIN FEATURES

Compact design.

Machined from bar stock materials or investment casting.

**OPTIONS:** Different soft valves for water and gases.  
 1/4" gauge connection on body.  
 Regulating screw with top cap.

**USE:** Compressed air, water and other gases and liquids compatible with the construction.

#### AVAILABLE MODELS:

PS30SS – Stainless steel.

**SIZES:** 1/2" to 2".  
 DN 15 to DN 50.

**CONNECTIONS:** Female threaded ISO 7 Rp or NPT.  
 Flanged EN 1092-1 PN40 or PN63.  
 Special flanges upon request.

**INSTALLATION:** Horizontal installation.  
 An "Y" strainer should be installed upstream the valve.  
 See IMI – Installation and maintenance instructions.

#### ORDER REQUIREMENTS:

Type of fluid.  
 Maximum operating temperature.  
 Required opening pressure capacity (maximum and minimum).



PS30SS 1/2" – DN 15

CE MARKING – GROUP 2 (PED – European Directive)	
PN40 / PN63	Category
1/2" to 1 1/4" – DN 15 to 32	SEP
1 1/2" to 2" – DN 40 to 50	1 (CE marked)

CAPACITIES						
Valve size (DN)	15	20	25	32	40	50
Kvs (m <sup>3</sup> /h)	2,1	2,4	6,5	7,2	12,7	13,7

LIMITING CONDITIONS	
Valve model	PS30SS
Body design conditions	PN63
Max. upstream pressure	15 bar
Min. upstream pressure	0,2 bar
Max. design temperature *	80 °C

\* Others on request

**Warning: Sustaining valves are not a substitute for safety valves or vacuum relief valves.**

**DIMENSIONS (mm) - THREADED**

SIZE	A	B	C	WGT. (kg)
1/2" – DN 15	80	38	175	1,8
3/4" – DN 20	80	38	175	1,8
1" – DN 25	105	66	250	6,3
1 1/4" – DN 32	125	66	250	7,5
1 1/2" – DN 40	205	86	270	13
2" – DN 50	201	80	274	13,3

Different face to face dimensions.

**DIMENSIONS (mm) - FLANGED**

SIZE	PN16/40			PN63 / PN100			
	D *	E	WGT. (kg)	D *	E PN63	E PN100	WGT. (kg)
1/2" – DN 15	150	47,5	3,2	210	52,5	52,5	4
3/4" – DN 20	150	52,5	3,8	230	70	70	6
1" – DN 25	160 (230)	57,5	8,5 (10,5)	230	70	70	12,8
1 1/4" – DN 32	260	70	11,4	260	77,5	77,5	14,4
1 1/2" – DN 40	200	75	16,3	260	85	85	20,3
2" – DN 50	230 **	82,5	18,5	300	90	97,5	22,8

\* Different lengths and ANSI flanges available on request.

\*\* Only available with flat flanges EN 1092-1 type 01 A. Welding neck type 11 B flanges as option with 300 mm minimum face to face dimensions.

( ) : Alternative.

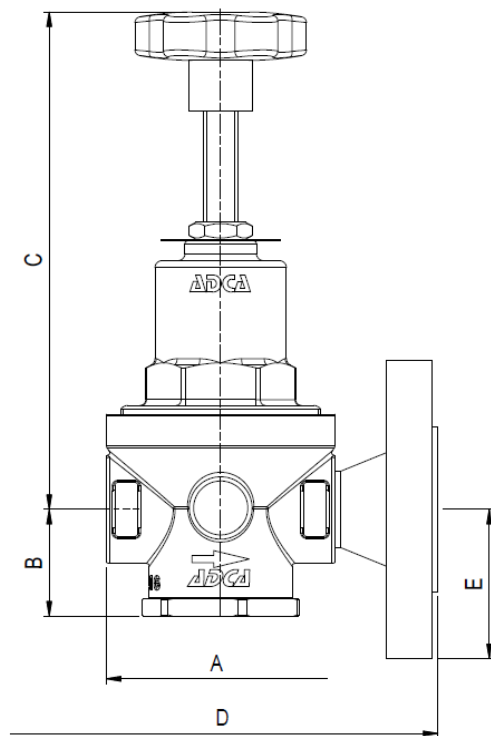

**MATERIALS**

POS. N°	DESIGNATION	MATERIAL
1	Valve body (a)	CF8M / 1.4408 (AISI 316 / 1.4401)
2	Top cover (b)	CF8M / 1.4408 (AISI 316 / 1.4401)
3	Seat cover (a)	CF8M / 1.4408 (AISI 316 / 1.4401)
4	* O-ring	NBR
5	Valve seat	AISI 316 / 1.4401
6	Sealing	NBR
7	* O-ring	NBR / EPDM / PTFE, etc.
9	Valve plug	AISI 316 / 1.4401
10	* Diaphragm	PTFE
11	* Diaphragm	NBR
11A	* O-ring	NBR / EPDM / PTFE, etc.
12	Gasket	Aluminium
13	Spring plate	AISI 304 / 1.4301
14	Nut	Stainless steel A2-70
15	* Adjustment spring	Spring steel
16	Top spring plate	Brass
17	Adjustment screw	AISI 304 / 1.4301
18	Locknut	Stainless steel A2-70
19	Handwheel	Plastic
20	Spring Id. plate	Aluminium

\* Available spare parts.

Remarks: All valves have a serial number. In case of non-standard valves this number must be supplied if spare parts are ordered.

a) Bar stock execution on request (standard for sizes DN 32 to DN 50).

b) Bar stock execution on request.

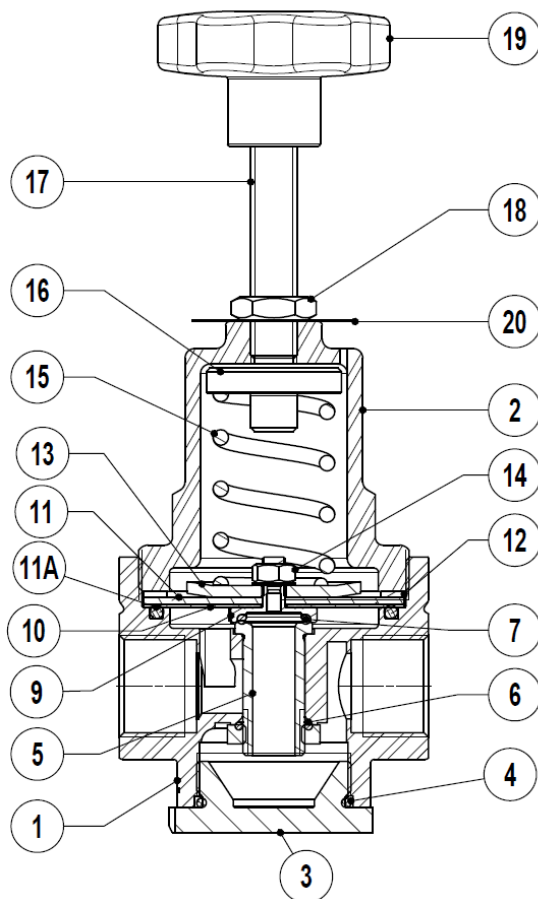

ORDERING CODES PS30SS												
Valve model	PS30	.	1	W	N	C	R	.	.	A	15	
PS30SS – Diaphragm sensing	PS30											
<b>Inlet spring range</b>												
N°1 – 0,2 to 1,5 bar			1									
N°2 – 0,3 to 3 bar			2									
N°3 – 0,8 to 8 bar			3									
N°4 – 1,5 to 15 bar			4									
<b>Application</b>												
Water				W								
Gases				G								
Oxygen (degreased)				O								
<b>Seal material</b>												
NBR					N							
EPDM					E							
PTFE					T							
FPM / Viton					V							
<b>Maximum inlet pressure</b>												
15 bar						C						
<b>Diaphragm material</b>												
Rubber / PTFE							R					
<b>Gauge port 1/4"</b>												
Without gauge ports								(1)				
Gauge port on the left side (relative to the flow direction)								4				
Gauge port on the right side (relative to the flow direction)								3				
Gauge ports on both sides								2				
<b>Relieving</b>												
Non-relieving									(1)			
Relieving									R			
<b>Pipe connection</b>												
Threaded ISO 7 Rp										A		
Threaded NPT ANSI B1.20.1										C		
Socket weld SW ANSI B16.11										H		
Butt weld BW ANSI B16.25										I		
Flanged EN 1092-1 PN40										N		
Flanged EN 1092-1 PN63										O		
Flanged ANSI B16.5 150 lb										U		
Flanged ANSI B16.5 300 lb										V		
Flanged ANSI B16.5 600 lb										W		
<b>Size</b>												
1/2" or DN 15											15	
3/4" or DN 20											20	
...												
<b>Special valves / Extras</b>												
Full description or additional codes have to be added in case of non-standard combination.												E

(1) Omitted if a standard valve is requested.